

SR-8 DRAGON CLAW DESIGN COLD SAW BLADE

It has a uniquely designed angle that can be resharpening to extend cutting lifespan.

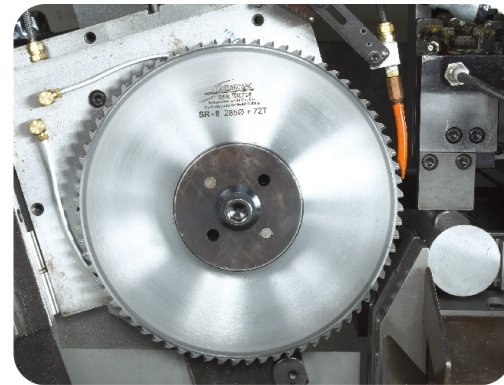

TECHNICAL NOTE

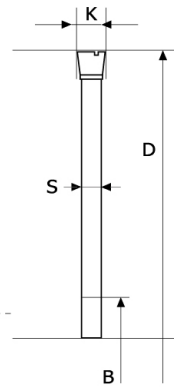
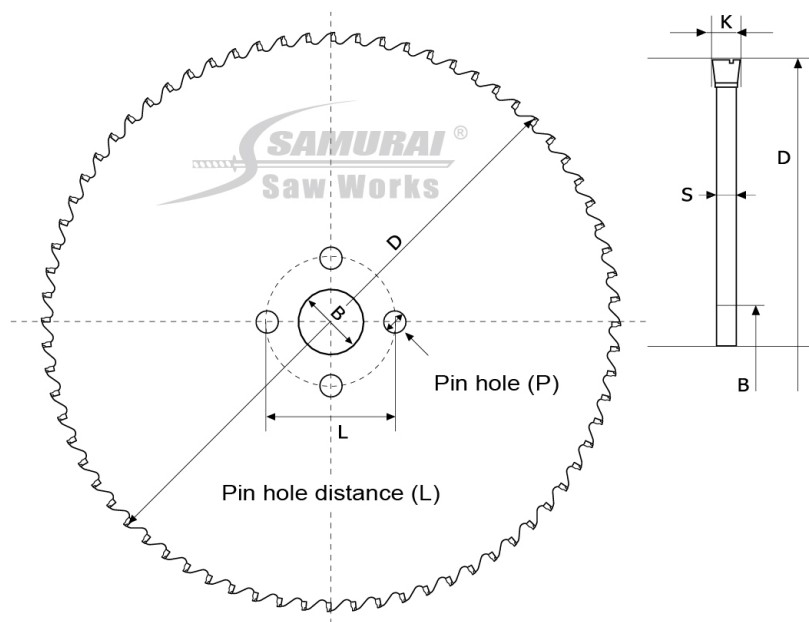
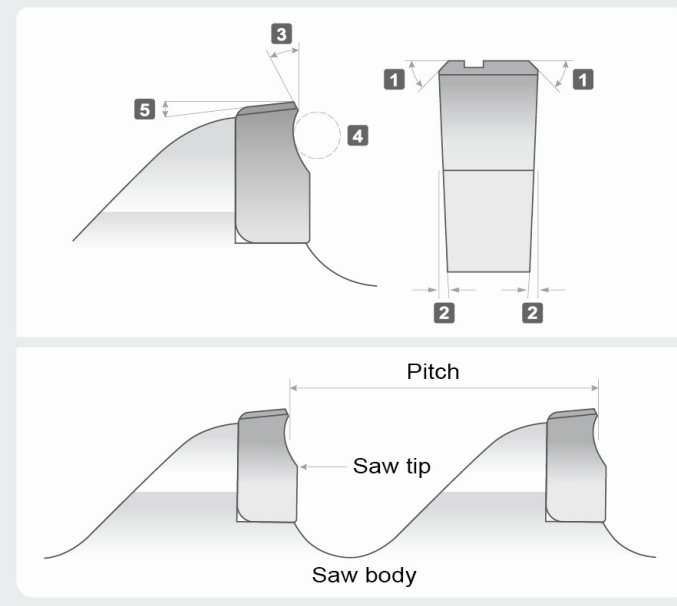

ANGLE DESIGNATION

Chamfer angle	1
Radial Clearance angle	2
Negative angle	3
Hook angle	4
Top angle	5
Saw Diameter	D
Bore hole	B
Pin hole Diameter	P
Pin hole Pitch	L
Kerf	K
Saw body thickness	S
Teeth of saw	T



SAMURAI
SAW WORKS CO.,LTD.
Cold sawblade for Metal Cutting



Samurai saw works co.,ltd

Tel: +886-4-2523-7009 Fax: +886-4-2523-8617
E-mail: service@samurai-saw.com
Web: www.samurai-saw.com
No.26, Lane. 535, Sec 2, Feng Shih Road,
Feng Yuan Dist, Taichung city, Taiwan 42085

- New saw blade
- Resharpener Center
- Cutting Center

Distributed agent by:



SR-8 Series

Retrieve the Cutting value for you

SR-8 series cold saw blade Resharpenable type

All New Evolution

THE NEW CUTTING-EDGE TECHNOLOGY!

SR-8 Dragon Claw Design Cold Saw Blade

- All new design, increased 30% more on cutting lifespan.
- Samurai saw blade is re-sharpenable! Every saw blade can be resharpening 6-12 times at least.
- Not only does Re-sharpened saw blade guarantees no loss from quality, but it also increases cutting lifespan and keeps the cost down.

SR-8 Dragon Claw Design Series

Standard Size List				
Diameter (D)	Thickness (S)	Kerf (K)	Bore hole (B)	Teeth (T)
240	1.75	2.0	32	60
				72
250	1.75 (1.7)	2.0	32	60
				72
				80
280	1.75 (1.7)	2.0	32	60
				72
				80
285	1.75 (1.7)	2.0	32 (40)	60
				72
				80
				100
				120
				140
315	2.0	2.3	32	60
				72
				80
				100
360	2.25	2.6	40 (50)	60
				72
				80
				100
				120
				140
380	2.25	2.6	50	60
				72
				80
420	2.25	2.6	50	60
				72
				80
460	2.25	2.7	50	60
				72
				80

★ Other size can customized if requested.

SR-8 Dragon Claw Design Cold Saw Blade

There has three types cold saw blade that developed for different cutting material.

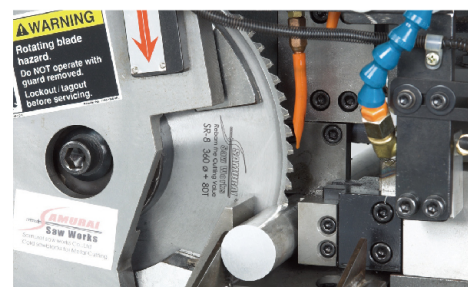

SR-8

- Best-Seller and regular product.
- Suitable for cutting solid alloy and carbon steel, Such as S45C (1045) \ SCM415 (4115)...and so on.

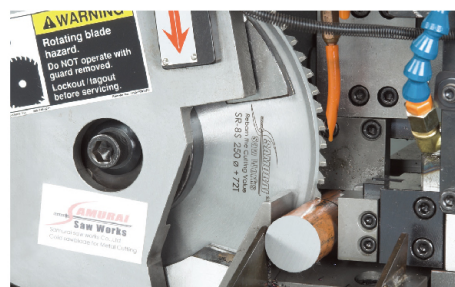

SR-8S Stainless cold Saw Blade

- Using tungsten carbide tips.
- Especially for cutting stainless steel (SUS) only.

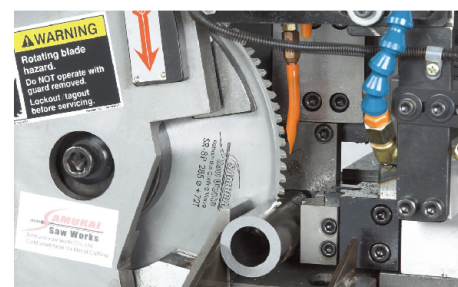

SR-8P Short Tips Cold Saw Blade

- Short tips type.
- Best choice for cutting pipe and tube.



SR-8

Suitable for cutting solid alloy and carbon steel.



SR-8S Stainless cold Saw Blade

Especially for cutting stainless steel (SUS) only.

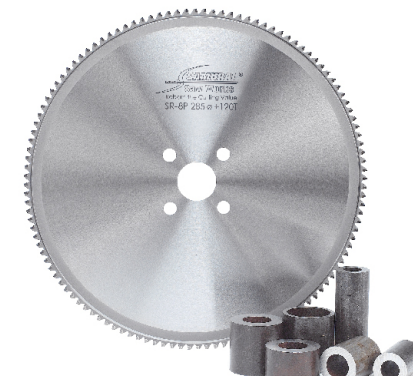

SR-8P Short Tips Cold Saw Blade

Best choice 120 teeth for cutting pipe and tube.

RETRIEVE the cutting value for you



Features of SR-8 Saw blade

1. New "Dragon Claw" design reinforces the combination of tips and saw body.
2. New "Bevel Wing" designs that reduce friction and extend cutting lifespan.
3. Using new NANO cermet carbide tips.
4. SR-8 has increased more 30% cutting lifespan than SR-7 after a long-term test.
5. Not only does Re-sharpened saw blade guarantees no loss from quality, but it also increases cutting lifespan and keeps the cost down.

Against tips lost



Against friction

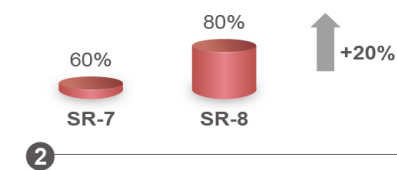

Fracture resistance

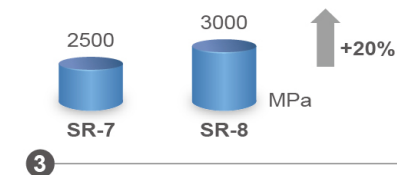

Cutting life

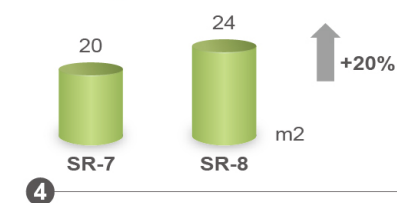

Resharpening result ★ Law quality loss

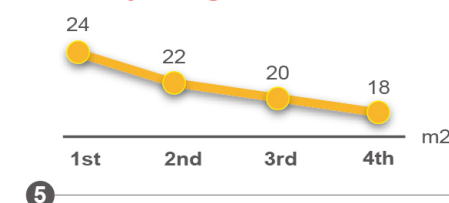

5



★ Patented product, counterfeiting not allowed.

WORLD UNIQUE DESIGN

New "Bevel Wing" design
New "Dragon Claw" design

